

FUTEK MODEL QLA305 CUSTOM DONUT LOAD CELL

STOCK NUMBER: QSH01198

INCH (mm)		R.O.= Rated Output	
WIRING CODE			
+Excitation	-Excitation	+Signal	-Signal
RED	BLACK	GREEN	WHITE
Shield			
FLOATING			

+ OUTPUT
(COMPRESSION)

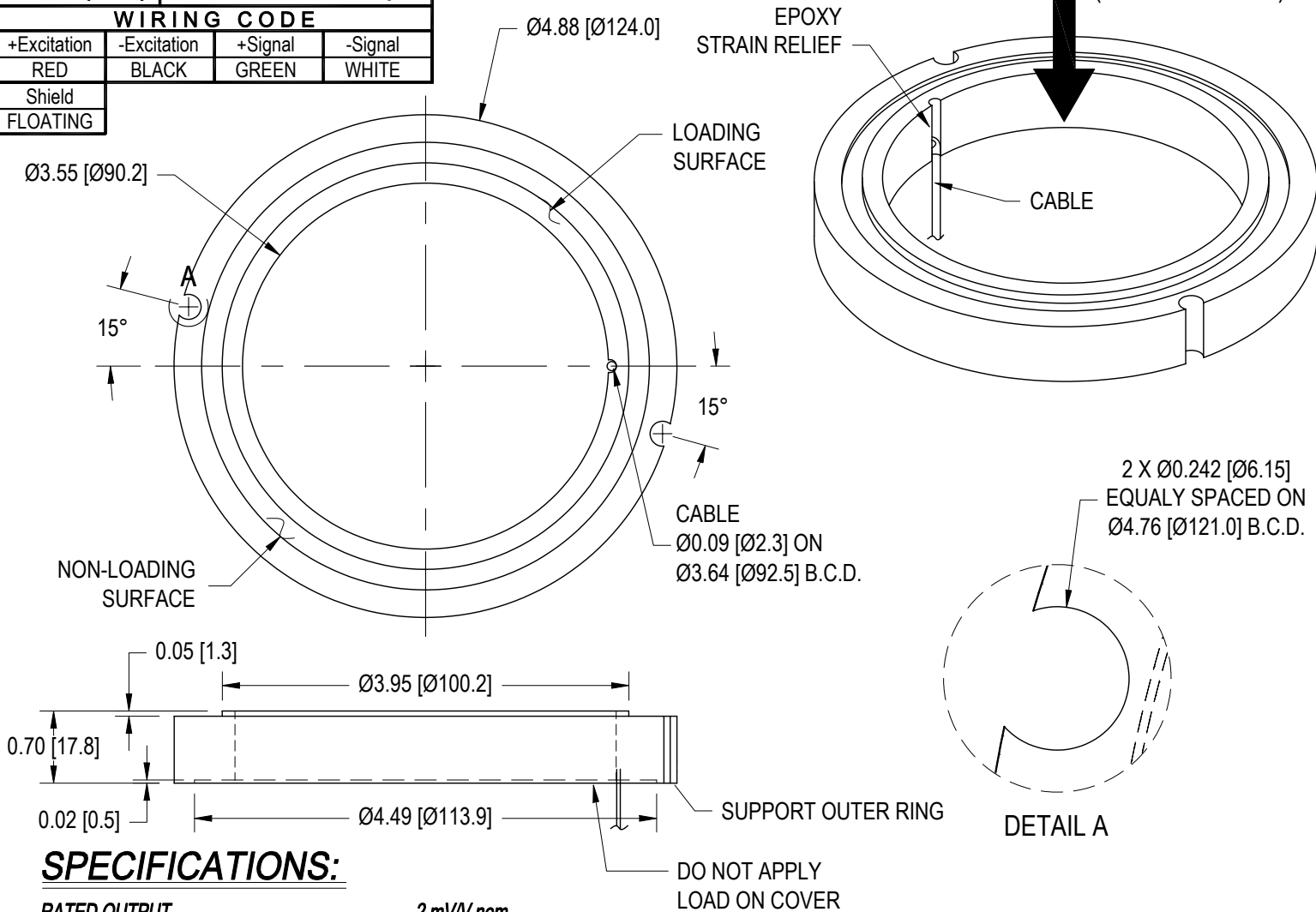

SPECIFICATIONS:

RATED OUTPUT	2 mV/V nom.
CAPACITY	75000 lbs
SAFE OVERLOAD	NONE
ZERO BALANCE	±3% of R.O.
EXCITATION (VDC OR VAC)	18 MAX
BRIDGE RESISTANCE	350Ω nom
NONLINEARITY	±3% of R.O.
NONREPEATABILITY	±0.5% of R.O.
TEMP. SHIFT ZERO	±0.02% of R.O./°F
TEMP. SHIFT SPAN	±0.02% of LOAD/°F
COMPENSATED TEMP.	60 to 160°F
OPERATING TEMP.	0 to 200°F
WEIGHT	1.5 lb
MATERIAL	STAINLESS STEEL
CABLE: #29 Awg 4 Conductor Spiral Shielded Silicone Cable, 10 ft Long	

NOTES:

- 1) SENSOR IS ENVIRONMENTALLY PROTECTED AGAINST AUTOMOTIVE OILS, WATER AND CONDUCTIVE DUST
- 2) WHILE TORQUING BOLTS, HIGH TENSION FORCES WILL OCCUR DURING INSTALLATION, WHICH COULD RESULT IN OVERLOADING THE SENSOR. FUTEK RECOMMENDS CONNECTING SENSOR TO A SYSTEM IN ORDER TO MONITOR THE APPLIED FORCES. FUTEK IS NOT LIABLE OR RESPONSIBLE FOR THE MISHANDLING OF THE SENSOR DURING INSTALLATION.

CUSTOMER APPROVAL-COMPANY
CUSTOMER APPROVAL-NAME /DATE
REVISIONS: (Refer to dwg # revision sheet)
9-19-08

OUTLINE DRAWING

STANDARD NOTES: (Unless Otherwise Specified)

- ALL DIMENSIONS ARE IN INCHES
- DRAWING INTERPRETATION DIMS. PER ASME-Y14.5M
- REMOVE BURRS AND BREAK SHARP EDGES .005 - .015
- THREADS PER HANDBOOK H-28
- DIMENSIONS ARE SHOWN AFTER PLATING

ANGLE: ±1/2°
CHAMFER: ±5°
TOLERANCE: .XX ±.01
.XXX ±.005

3rd ANGLE PROJ.

This drawing is submitted solely for the information and exclusive use of the original addressee. It is not to be divulged in whole or in part, by any firm or individual without written permission from:

FUTEK
ADVANCED SENSOR TECHNOLOGY, INC.
10 THOMAS
IRVINE, CA 92618 USA
Phone: (949) 465-0900
Fax: (949) 465-0905

CAGE: 1X8M6

MODEL: **QLA305** DWG No.: **FO1224**

DRAWN BY: R. WALKER CHECKED BY: -

APPROVED BY: J. VARGAS DATE: **Sept 16, 2008**